

By  
**Cheng Peng, Ph.D.**  
Video Applications Engineer;  
**Thanh Tran, Ph.D.**  
Embedded Systems Manager;  
Texas Instruments

## Overview

Digital signal processors (DSPs) handle the vast majority of video encoding applications unaided, implementing a scalable architecture that includes FPGAs as a co-processor to offload certain tasks that satisfy even the most demanding video applications.

# HD Video Encoding with DSP and FPGA Partitioning

As video and imaging applications evolve toward high-definition (HD) video compression standards, co-processing architectures that include both DSPs and FPGAs are becoming a more popular option. However, partitioned systems are not the only option because new advances in DSP architectures, performance, peripheral mix, video hardware acceleration and implementation techniques have significantly broadened the range of applications in which DSPs can provide a complete solution.

DSPs have an inherent advantage because they are programmable, and their versatility allows designers to execute almost any algorithm. But as the computational load grows exponentially, as is the case in HD video, FPGAs can sometimes be employed to off load the DSP of certain compute-intensive tasks that can be hard-wired into the FPGA.

In video encoding, as in virtually all engineering designs, there are no one-size-fits-all solutions.

Even when the same codec is being employed, the application plays a critical role in determining what level of computing power and memory bandwidth are required. This, in turn, can play a dominant role in both hardware and software implementation strategies.

When dealing with compressed video, utilizing a standard compression algorithm is the most likely choice for experienced design teams. Once a codec is selected, however, another critical step is to assess the requirements of motion estimation (ME) and motion compensation (MC) because they can be two of the most demanding functions in video compression.

Not surprisingly, the computational and memory bandwidth demands that roll out of the ME and MC engines depend on the amount of motion in the scene.

The H.264/AVC (advanced video coding) codec, for example, can be used in applications such as video surveillance where most often, very little action occurs over hours of surveillance. At the other end of the spectrum, encoding HD video for a broadcast application can require a memory bandwidth of 20 GBytes/s or higher.

Somewhere in between is HD video conferencing, which might require memory bandwidth of 1.5 GBytes/s.

## Encoding HD Video

Although profiles go a long way towards a “packaged” solution for design engineers, the specific application has at least an equal impact on the implementation’s hardware architecture.

An HD teleconferencing application, for example, can be expected to have relatively little motion from frame to frame, but a broadcast TV application must deal with the more intense video of sporting events, action movies and other content in which a substantial amount of motion can be expected.

As previously mentioned, the ME and MC engines are key elements in a hardware partitioning strategy, particularly for encoding video. The design team must consider whether the ME engine alone should be implemented on the FPGA or whether the computational load is heavy enough to require both the ME and MC engines for hardware acceleration.

The memory bandwidth, which can be 20 GBytes or higher, is just as important as the computational loading. FPGA hardware architects may have flexibilities to scale the memory bandwidth as high as necessary.

The H.264/AVC high profile is the obvious architecture for HD encoding of broadcast transmission. An illustration of the basic H.264/AVC encoder architecture is shown in Figure 1.

For ME calculations, the current frame and each of the frames it will be referenced to are both divided/broken into macroblocks (MB), which are typically 16-by-16 pixels but can be as small as 4-by-4 pixels. In a process called matching, a search attempts to locate the MB in the reference frame that satisfies a pre-determined minimum error criterion from

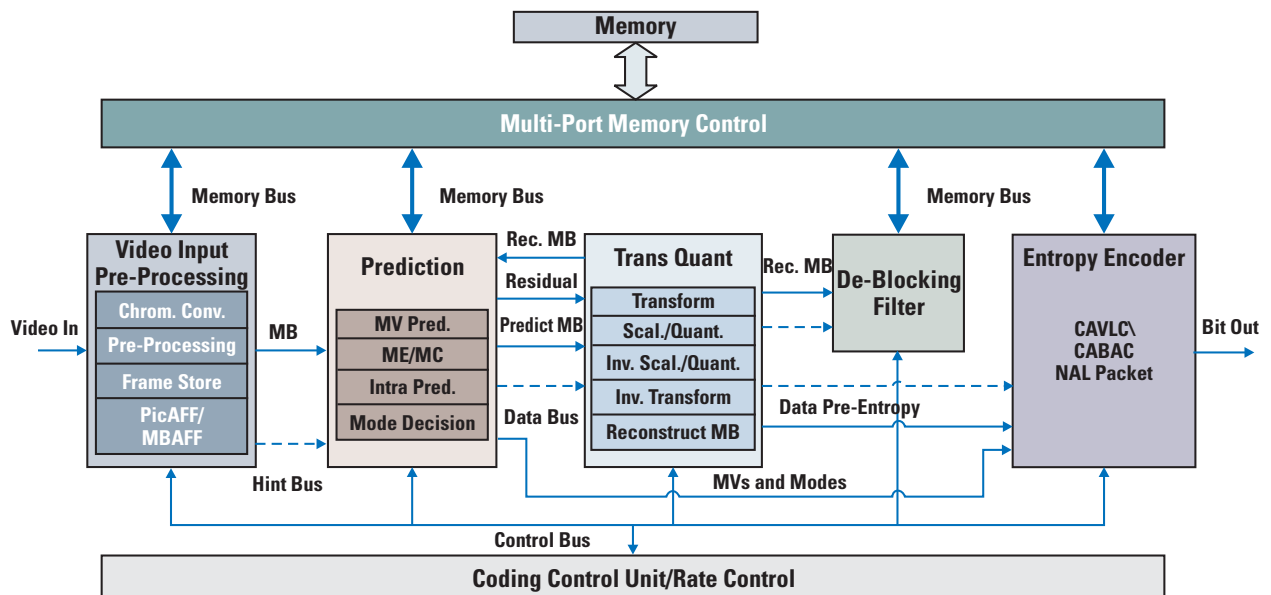

**Figure 1. The motion prediction block of the encoder is critical to hardware partitioning.**

the current frame. A common error criterion used by the ME engine is the Sum of Absolute Differences, or SAD, which is defined as:

$$SAD = \sum_{i=0}^{15} \sum_{j=0}^{15} |x_{ij} - y_{ij}|$$

where  $x$  is the current frame macro-block,  $y$  is the reference frame macro-block and  $ij$  denotes row  $i$ , column  $j$  of the frame.

In some applications, the ME engine may have to do only about 64 SAD calculations per cycle while in others it may have to execute thousands of SADs per cycle. The difference is quite significant and at the high end, it can lead to employing architectures that feature multiple DSPs or call for partitioning some of the calculations in a hardwired accelerator on an FPGA.

Regardless of whether the FPGA is needed to calculate SADs or for its memory bandwidth, in order for the FPGA to be effective it has to have tightly coupled communication with the DSP. Figure 2 illustrates a technique called macroblock-based pipeline processing, which addresses this design challenge.

The P-frame (middle) is a video frame encoded relative to the past reference frame. A reference frame is a P- or I-frame (top). The past reference frame is the closest preceding reference frame.

More important from a hardware architecture perspective is that in the DSP and FPGA solution, internal buffers are reserved for multiple macroblocks. While one macroblock is being processed and written to an internal buffer, the macroblock data in the other buffers (that has already been processed) is transmitted to the subsequent processing unit.

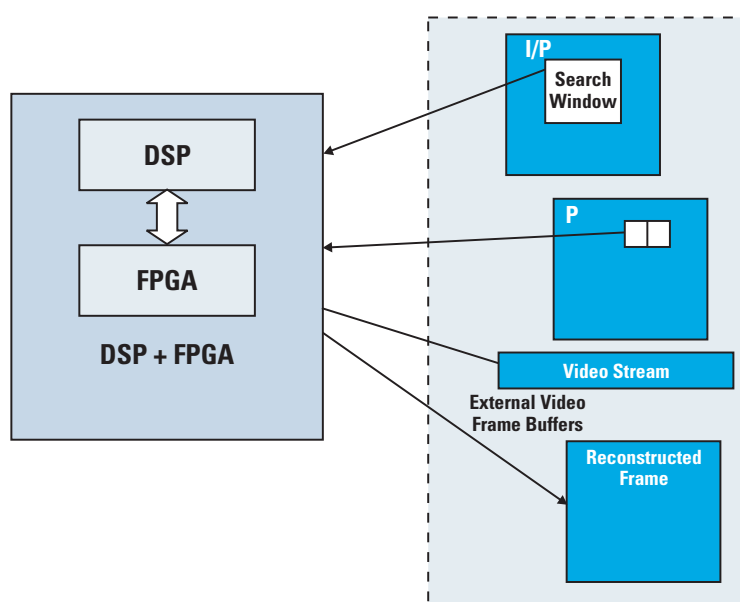

**Figure 2. Macroblock-based pipeline processing.**

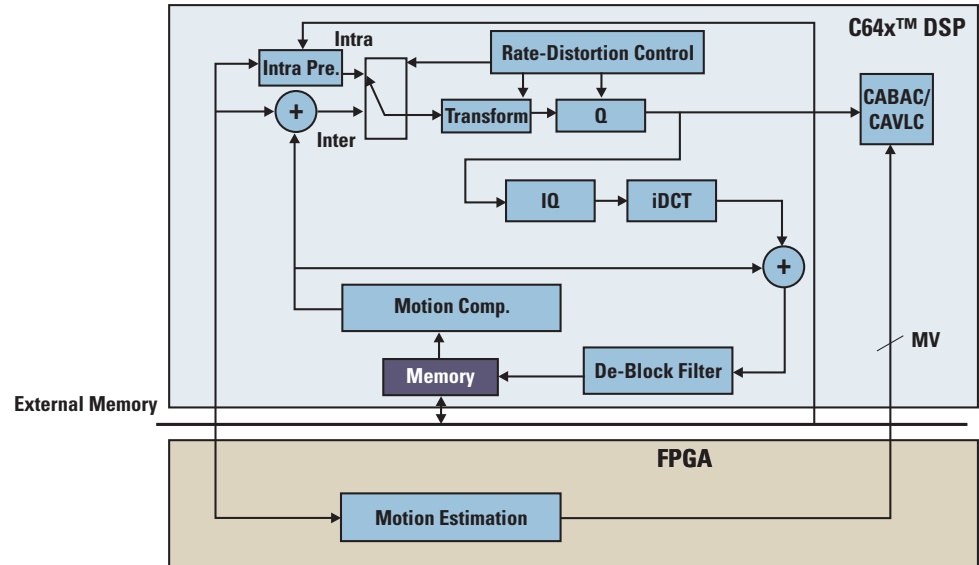

**Figure 3a. Architecture A needs straightforward DSP-FPGA communication protocols.**

In a synchronous design, it is very important for the DSP and FPGA to access memory in a particular order and granularity while minimizing the number of clock cycles due to latency, bus contention, alignment, DMA transfer rate and the types of memory.

Inter-chip communication is critical in the implementation model. Figures 3a and 3b show two optional architectures. Architecture A implements only the ME engine on the FPGA while architecture B implements both the ME and MC engines. An additional complexity is added by the fact that the ME engine and the MC engine must continuously interact with each other.

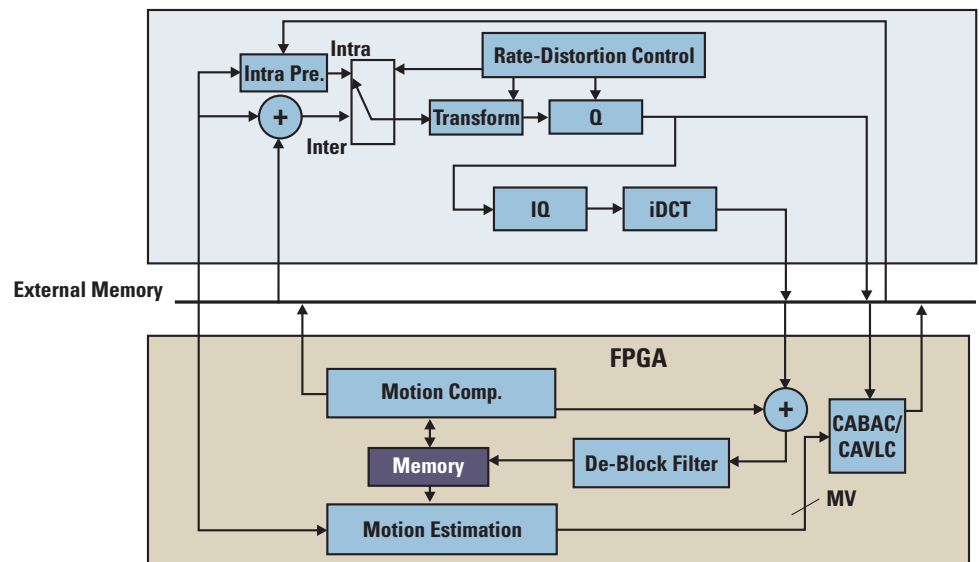

**Figure 3b. Architecture B significantly increases DSP/FPGA/memory interactions.**

Architecture B moves more than just the ME engine to the FPGA. The memory buffer, de-blocking filter, and the CABAC/CAVLC block go along with it. The context-adaptive binary arithmetic coding (CABAC) is a clever technique to compress syntax elements in the video stream. Context-adaptive variable-length coding (CAVLC) is a lower-complexity alternative to CABAC for the coding of quantized transform coefficient values.

While architecture B keeps a good balance of functionalities among the DSP and FPGA and enables both high performance and improved flexibility for H.264/AVC encoding, it should be avoided when possible because memory data transfer and communication protocol can be very complicated between the DSP and FPGA.

Architecture A is the optimal choice since it keeps memory data transfer and the communication protocol between the DSP and FPGA simple.

## **H.264/AVC Encoding of Broadcast Video**

Broadcast video encoding requires a different peripheral mix than encoders in consumer devices and relatively undemanding encoders such as video conferencing. High-end encoders need high channel densities and throughput along with low cost per channel. The right peripherals and memory go far towards reaching these goals.

Peripherals, such as Serial RapidIO<sup>®</sup> (SRIO), gigabit Ethernet interface, DDR2 and larger L2 memory, all available on the TI's TMS320C6455 DSP, are more relevant to DSP and FPGA partitioning decisions and can allow designers to create high-performance applications by integrating multiple DSPs on the same board.

An SRIO bus decreases overall system cost by reducing the need for additional devices used for switching and processor aggregation. SRIO interconnect also enables high-speed, packet-switched, peer-to-peer connectivity, providing a performance breakthrough for multi-channel implementations on multiple processors.

A 1× SRIO link is fast enough to send HD 1080i raw video between devices, and a 4× SRIO link can easily send HD 1080p raw video between devices with bandwidth to spare. The use of SRIO in infrastructure applications with "DSP farms" can significantly cut system cost (device count, board size and/or device cost).

In addition to SRIO, the DSP should integrate high-bandwidth peripherals such as the gigabit EMAC, DDR2 and 2 MB of L2 memory. A gigabit EMAC has ten times more Ethernet bandwidth than earlier generation devices.

A 500-MHz DDR2 external memory interface provides twice the throughput, allowing system designers to transfer in data at a faster rate. Finally, the 2 MB of L2 memory enables extra performance, further reducing the price per channel in infrastructure applications.

## Scalable Systems

Integrating high-bandwidth I/O blocks into the DSP has the expected result of adding another design option. With the availability of DSPs capable of satisfying the memory bandwidth of real-time HD encoding of broadcast video, the designer should consider using multiple DSPs in even more scenarios instead of an inherently complex DSP and FPGA combination.

The primary reason for using two DSPs for HD encoding is that the inter-chip communications have been largely solved by the chip designers. Another reason is scalability.

Since the evolution to HD has really only just begun, in many instances designers will find it useful to provide a standard definition (SD) solution that can be scaled to an HD solution with little additional effort. Employing DSPs with high-performance I/O such as SRIO offers an easy migration path.

The starting point in this scalability strategy is encoding SD video. A single 1-GHz DSP with the peripherals mentioned above is capable of encoding H.264/AVC's SD baseline profile at 720×480 pixel resolution and 30 frames per second (fps). Motion compensation is executed on chip.

When the encoding requirement moves to HD, two 1-GHz DSPs can be employed with SRIO utilized for interprocessor communication. ME and MC are moved off the chip that originally handled the SD encoding alone. Figure 4a shows the SD encoding architecture and Figure 4b shows its evolution to HD encoding at 1280×720 resolution, 30 fps.

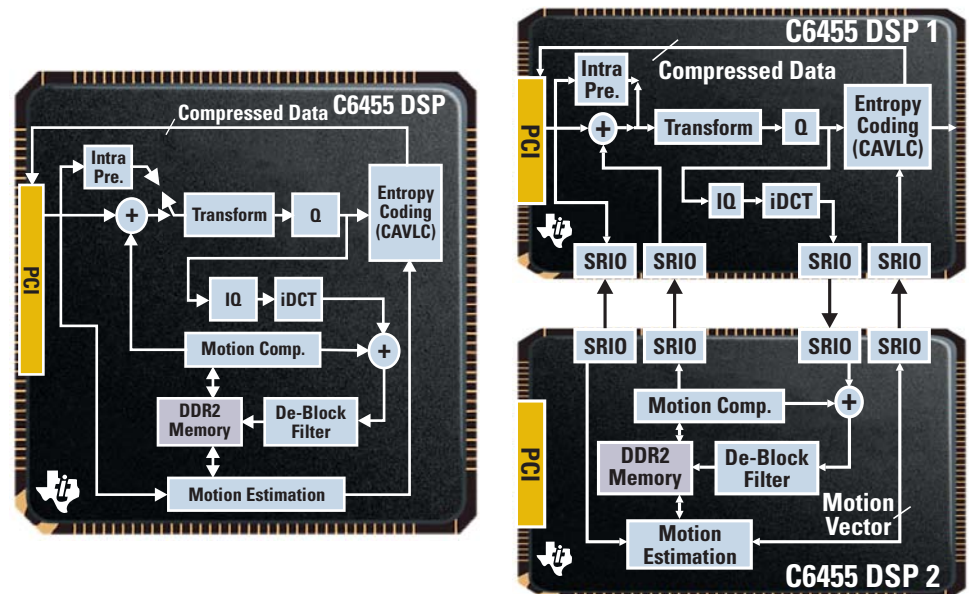
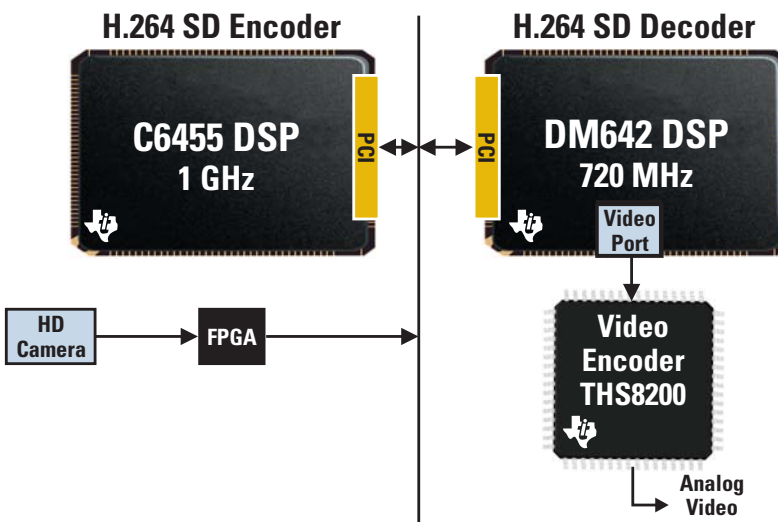

Figure 4a. SD encoding with 1-GHz DSP.

Figure 4b. HD encoding with 1-GHz DSP.

Note that in these two designs, FPGA-assist is not required.

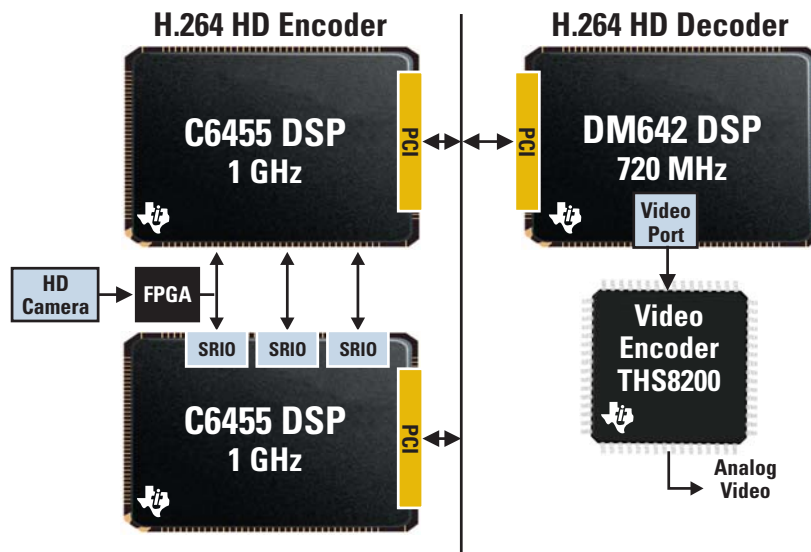

**Figure 5a. SD encode and decode system.**

When the design scenario moves to an application where encode and decode are both required in the same system, DSPs can still be utilized to do a majority of the work.

For SD decode and encode, an FPGA is used as a buffer for the video from the camera and a less-expensive media processor such as TI's TMS320DM642 digital media processor running at 720 MHz can be used for decoding.

HD encode and decode employs fundamentally the same architecture as that of HD encoding (Figure 4b) but with the addition of the low-cost, high-performance media processor and an FPGA. Figures 5a and 5b illustrate these evolutionary steps. The HD system can perform simultaneous H.264/AVC, baseline profile, HD encoding and decoding at 1280×720, 30 fps.



**Figure 5b. HD encode and decode system.**

One of the first DSPs to reach the level of integration for HD encoding is TI's TMS320C6455 DSP with an SRIO bus to provide chip-level inter-connect and processor-to-processor communication up to 10 Gbits per second full-duplex interconnectivity.

SRIO makes multiprocessing architectures easier to implement and using two or more C6455 DSPs on the same board assures that there are no computing bottlenecks. A board with 10 C6455 DSPs clocking 1 GHz and working in parallel will achieve 10 GHz of performance. The board can also be designed to support multiple I/O modules such as SRIO, HD SDI and CameraLink.

As high-end video applications continue to demand higher channel densities, throughput and lower cost per channel, design teams must evaluate more diverse architectural options. Developers no longer need to team a DSP with a FPGA to utilize the memory bandwidth and hardware accelerators of FPGA. Instead, they can employ a new generation of DSPs such as the C6455 DSP, which has integrated several high-speed peripherals, the most important of which is SRIO. High-performance video encoder requirements can usually be met by deploying several DSPs on the same board and, since the chips all run the same embedded operating system and have been designed to work together, the chip-to-chip communications challenge is significantly reduced.

Important Notice: The products and services of Texas Instruments Incorporated and its subsidiaries described herein are sold subject to TI's standard terms and conditions of sale. Customers are advised to obtain the most current and complete information about TI products and services before placing orders. TI assumes no liability for applications assistance, customer's applications or product designs, software performance, or infringement of patents. The publication of information regarding any other company's products or services does not constitute TI's approval, warranty or endorsement thereof.

RapidIO is a registered trademark of RapidIO Trade Association. All other trademarks are the property of their respective owners.

## IMPORTANT NOTICE

Texas Instruments Incorporated and its subsidiaries (TI) reserve the right to make corrections, modifications, enhancements, improvements, and other changes to its products and services at any time and to discontinue any product or service without notice. Customers should obtain the latest relevant information before placing orders and should verify that such information is current and complete. All products are sold subject to TI's terms and conditions of sale supplied at the time of order acknowledgment.

TI warrants performance of its hardware products to the specifications applicable at the time of sale in accordance with TI's standard warranty. Testing and other quality control techniques are used to the extent TI deems necessary to support this warranty. Except where mandated by government requirements, testing of all parameters of each product is not necessarily performed.

TI assumes no liability for applications assistance or customer product design. Customers are responsible for their products and applications using TI components. To minimize the risks associated with customer products and applications, customers should provide adequate design and operating safeguards.

TI does not warrant or represent that any license, either express or implied, is granted under any TI patent right, copyright, mask work right, or other TI intellectual property right relating to any combination, machine, or process in which TI products or services are used. Information published by TI regarding third-party products or services does not constitute a license from TI to use such products or services or a warranty or endorsement thereof. Use of such information may require a license from a third party under the patents or other intellectual property of the third party, or a license from TI under the patents or other intellectual property of TI.

Reproduction of TI information in TI data books or data sheets is permissible only if reproduction is without alteration and is accompanied by all associated warranties, conditions, limitations, and notices. Reproduction of this information with alteration is an unfair and deceptive business practice. TI is not responsible or liable for such altered documentation. Information of third parties may be subject to additional restrictions.

Resale of TI products or services with statements different from or beyond the parameters stated by TI for that product or service voids all express and any implied warranties for the associated TI product or service and is an unfair and deceptive business practice. TI is not responsible or liable for any such statements.

TI products are not authorized for use in safety-critical applications (such as life support) where a failure of the TI product would reasonably be expected to cause severe personal injury or death, unless officers of the parties have executed an agreement specifically governing such use. Buyers represent that they have all necessary expertise in the safety and regulatory ramifications of their applications, and acknowledge and agree that they are solely responsible for all legal, regulatory and safety-related requirements concerning their products and any use of TI products in such safety-critical applications, notwithstanding any applications-related information or support that may be provided by TI. Further, Buyers must fully indemnify TI and its representatives against any damages arising out of the use of TI products in such safety-critical applications.

TI products are neither designed nor intended for use in military/aerospace applications or environments unless the TI products are specifically designated by TI as military-grade or "enhanced plastic." Only products designated by TI as military-grade meet military specifications. Buyers acknowledge and agree that any such use of TI products which TI has not designated as military-grade is solely at the Buyer's risk, and that they are solely responsible for compliance with all legal and regulatory requirements in connection with such use.

TI products are neither designed nor intended for use in automotive applications or environments unless the specific TI products are designated by TI as compliant with ISO/TS 16949 requirements. Buyers acknowledge and agree that, if they use any non-designated products in automotive applications, TI will not be responsible for any failure to meet such requirements.

Following are URLs where you can obtain information on other Texas Instruments products and application solutions:

| <b>Products</b>       |                                                                    | <b>Applications</b> |                                                                          |
|-----------------------|--------------------------------------------------------------------|---------------------|--------------------------------------------------------------------------|
| Amplifiers            | <a href="http://amplifier.ti.com">amplifier.ti.com</a>             | Audio               | <a href="http://www.ti.com/audio">www.ti.com/audio</a>                   |
| Data Converters       | <a href="http://dataconverter.ti.com">dataconverter.ti.com</a>     | Automotive          | <a href="http://www.ti.com/automotive">www.ti.com/automotive</a>         |
| DSP                   | <a href="http://dsp.ti.com">dsp.ti.com</a>                         | Broadband           | <a href="http://www.ti.com/broadband">www.ti.com/broadband</a>           |
| Interface             | <a href="http://interface.ti.com">interface.ti.com</a>             | Digital Control     | <a href="http://www.ti.com/digitalcontrol">www.ti.com/digitalcontrol</a> |
| Logic                 | <a href="http://logic.ti.com">logic.ti.com</a>                     | Military            | <a href="http://www.ti.com/military">www.ti.com/military</a>             |
| Power Mgmt            | <a href="http://power.ti.com">power.ti.com</a>                     | Optical Networking  | <a href="http://www.ti.com/opticalnetwork">www.ti.com/opticalnetwork</a> |
| Microcontrollers      | <a href="http://microcontroller.ti.com">microcontroller.ti.com</a> | Security            | <a href="http://www.ti.com/security">www.ti.com/security</a>             |
| RFID                  | <a href="http://www.ti-rfid.com">www.ti-rfid.com</a>               | Telephony           | <a href="http://www.ti.com/telephony">www.ti.com/telephony</a>           |
| Low Power<br>Wireless | <a href="http://www.ti.com/lpw">www.ti.com/lpw</a>                 | Video & Imaging     | <a href="http://www.ti.com/video">www.ti.com/video</a>                   |
|                       |                                                                    | Wireless            | <a href="http://www.ti.com/wireless">www.ti.com/wireless</a>             |

Mailing Address: Texas Instruments, Post Office Box 655303, Dallas, Texas 75265  
Copyright © 2007, Texas Instruments Incorporated